













## DATI TECNICI

	Peso totale*	17600 kg		Sbraccio massimo di lavoro	31 m
	Lunghezza complessiva	9,92 m		Rotazione torretta	540°
	Larghezza in posizione di trasporto	2,51 m		Rotazione cestello	2 x 200°
	Altezza in posizione di trasporto	3,96 m		Angolo operativo del jib	240°
	Larghezza max. stabilizzatori	6,30 m		Dimensioni cestello	3,88 x 1,05 x 1,10 m
	Max. altezza di lavoro	48 m		Portata max. cestello	600 kg
	Max. altezza di lavoro dal piano di calpestio cestello	46 m			

\* In funzione dell'autocarro

## DIAGRAMMI DI LAVORO

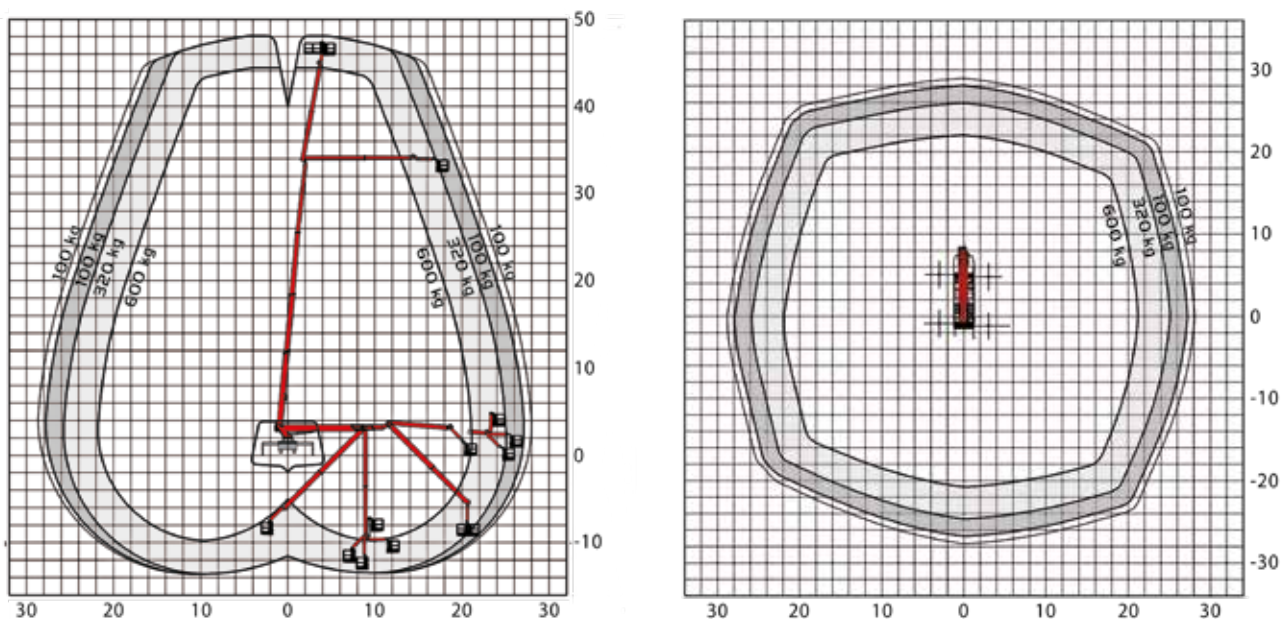





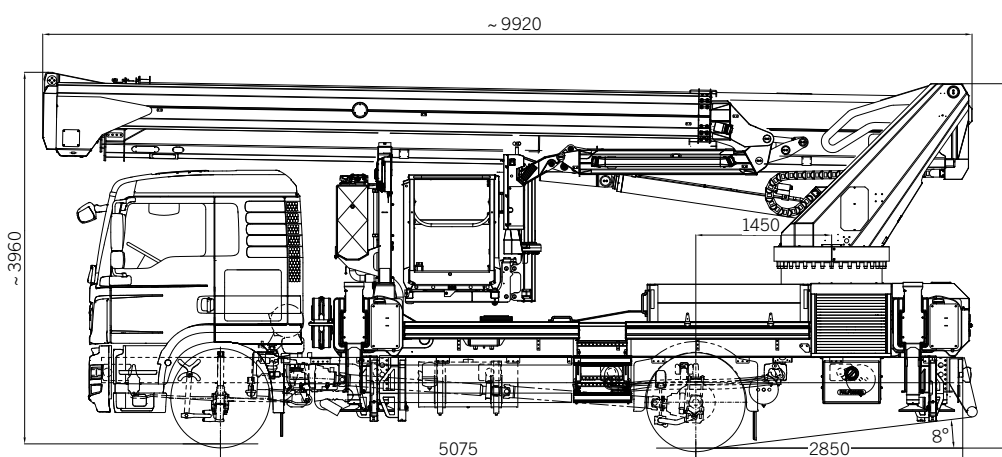







Un'eventuale tolleranza del 2% in funzione della struttura

## DIMENSIONI



## CARACTÉRISTIQUES TECHNIQUES – AJOUTER DES PICTOGRAMMES

	Poids maximal *	17600 kg		Portée max.	31 m
	Longueur de transport	9,92 m		Zone de rotation de la tourelle	540°
	Largeur de transport	2,51 m		Angle de rotation de la nacelle élévatrice	2 x 200°
	Hauteur de transport	3,96 m		Angle de rotation du jib	240°
	Largeur max. d'appu	6,30 m		Taille du Panier	3,88 x 1,05 x 1,10 m
	Hauteur max. de travail	48 m		Charge utile max. du Panier	600 kg
	Hauteur de plancher max. de la nacelle	46 m			

\* en fonction du châssis du camion

## DIAGRAMME DE TRAVAIL – REPRÉSENTATION EN COULEUR

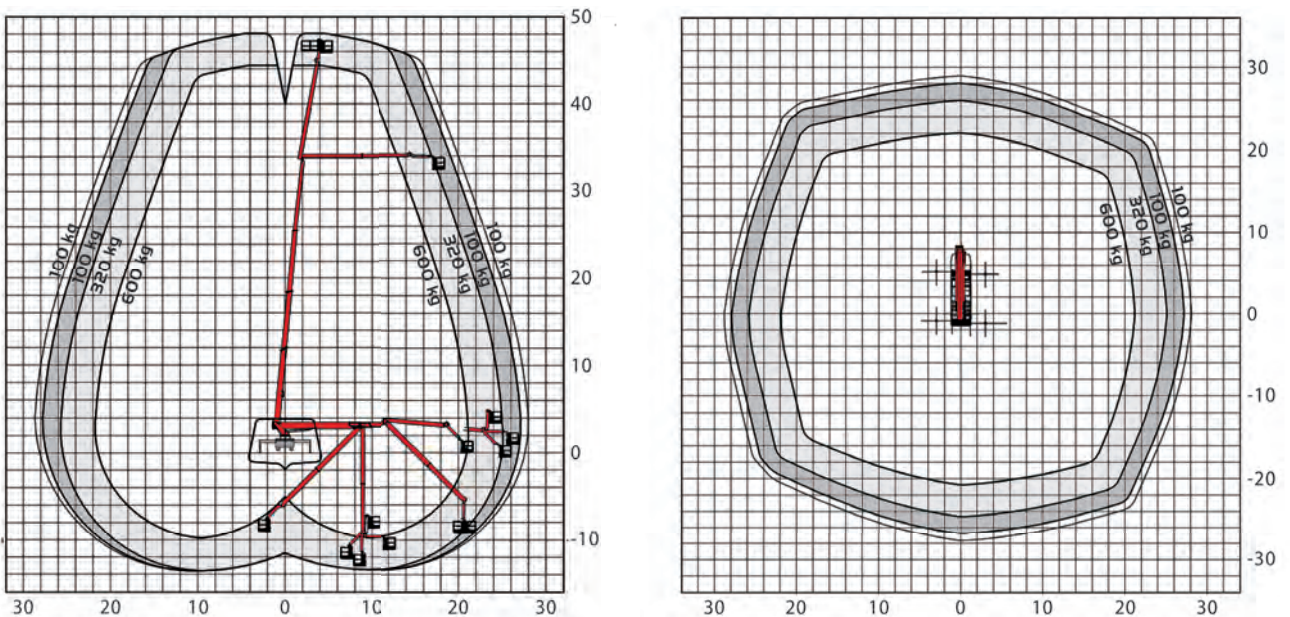





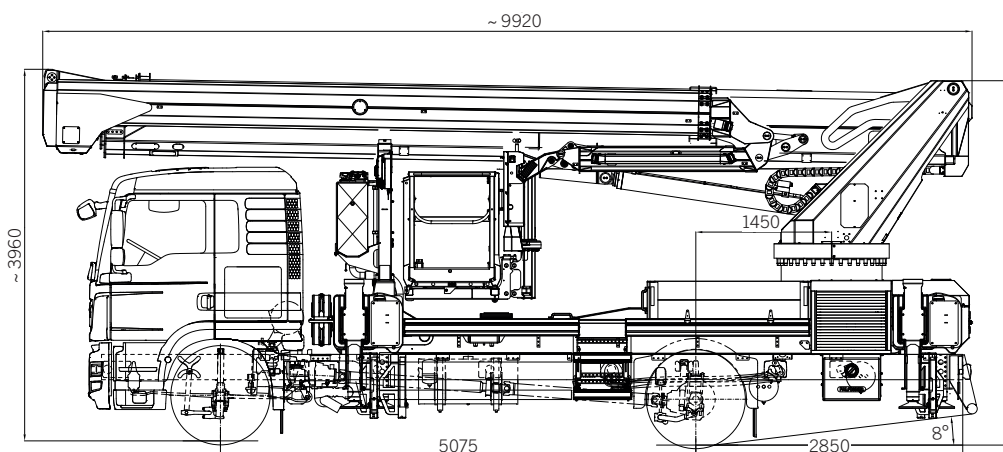







tolérance de 2 % possible due aux composants

## DIMENSIONS



## TECHNICAL SPECIFICATIONS

	Total weight *	17600 kg		max. outreach	31 m
	Overall length	9,92 m		Rotation angle of turntable	540°
	Width in transportposition	2.51 m		Rotation angle of cage	2 x 200°
	Height in transportposition	3.96 m		Rotation angle of cage boom	240°
	max. stabiliser width	6.30 m		Size of cage	3.88 x 1.05 x 1.10 m
	max. working height	48 m		max. cage load	600 kg
	max. cage bottom height	46 m			

\* Depends on truck chassis

## WORKING DIAGRAMS

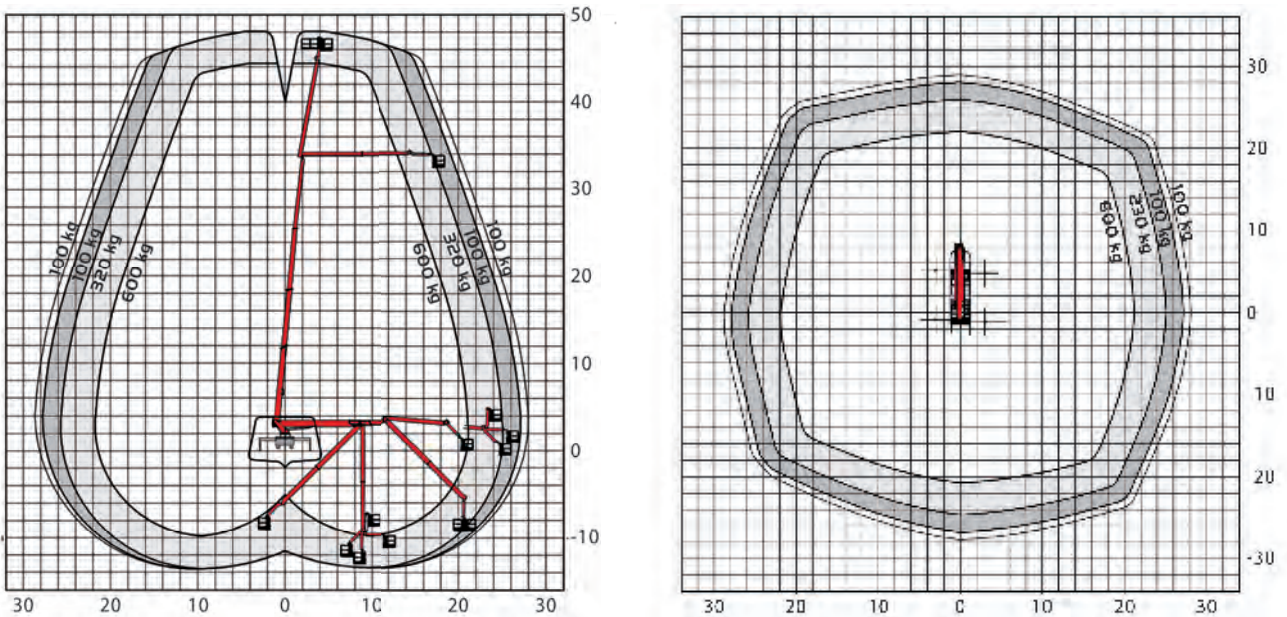

A possible 2% tolerance is contingent on structural components

## DIMENSIONS

